



**BRV0443SDH.AUXX**

**4 X 432x343**



**DIGITAL  
DIGITAL**

PRICE - PREIS  
**€ 1.850,00**

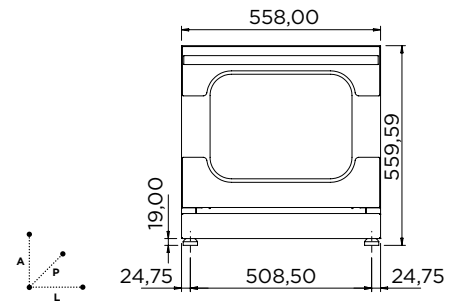

<b>DIMENSION AND WEIGHT NET GRÖSSE UND GEWICHT NETTO</b>	<b>L 558 mm - P 644 mm - A 560 mm - kg 34</b>	
<b>DIMENSION AND WEIGHT GROSS GRÖSSE UND GEWICHT BRUTTO</b>	<b>L 600 mm - P 660 mm - A 600 mm - kg 39</b>	
<b>POWER - LEISTUNG</b>	2,8 kW	
<b>ELECT. CONNECTION - STROMANSCHLUSS</b>	220-240V 50/60 HZ	
<b>CAPACITY GRIDS/TRAY - KAPAZITÄT ROSTE/BLECHE</b>	4 X 432x343	
<b>SPACE BETWEEN TRAYS ABSTAND ZWISCHEN DEN BLECHEN</b>	68,5 mm	
<b>NUMBER OF FANS - ANZAHL LÜFTER</b>	1	
<b>FAN SPEED - LÜFTERGECHWINDIGKEIT</b>	1	
<b>TEMPÉRATURE MAXIMALE - TEMPERATURA MÁXIMA</b>	270°C	
<b>WATER MAINS HUMIDIFICATION BEFEUCHTUNG DES WASSERNETZES</b>	As standard - Serienmäßig	
<b>HUMIDIFICATION WITH PUMP BEFEUCHTUNG MIT PUMPE</b>	12P	<b>€ 50,00</b>
<b>TEMPERATURE CONTROL - TEMPERATURSTEUERUNG</b>	Electronic - Elektronisch	
<b>OPEN DOOR DIRECTION - TÜRÖFFNUNG</b>	Downward door - Klapptür	

<b>ACCESSORIES - ZUBEHÖR</b>		
<b>SUPPORT - UNTERBAU KOMBIDÄMPFER</b>	<b>SUP800</b>	<b>€ 770,00</b>
<b>CONTAINER - WANNE</b>	<b>KITUMI90006</b>	<b>€ 40,00</b>
<b>CLOUD SUBSCRIPTION (2 YEARS SUBSCRIPTION + WI-FI CARD) CLOUD-ABONNEMENT (2 JAHRE ABONNEMENT + WIFI-KARTE)</b>	-	

A Decalcified water inlet 3/4" - Eintritt entkalktes Wasser 3/4" - B Power supply - Stromversorgung - C Rear panel removable - Rückwand Abnehmbar - D Equipotential point - Potentialausgleich - E Steam breather Ø 30mm - Dampfablaßventil Ø 30mm

